

# BCT1410

## 2A, Step-Down, DC to DC Converter

### GENERAL DESCRIPTION

The BCT1410 is a monolithic step-down switch mode regulator with a built in internal Power MOSFET. It achieves 2A continuous output current over a wide input supply range with excellent load and line regulation.

Current mode operation provides fast transient response and eases loop stabilization.

Fault condition protection includes cycle-by-cycle current limiting and thermal shutdown. In shutdown mode the regulator draws 25uA of supply current.

The BCT1410 requires a minimum number of readily available standard external components.

This device, available in an 8-pin SOIC package, provides a very compact solution with minimal external components.

### FEATURES

- 2A Output Current
- 0.22 Internal Power MOSFET Switch
- Stable with Low ESR Output Ceramic capacitors
- Up to 95% Efficiency
- 20uA Shutdown Mode
- Fixed 380KHz frequency
- Thermal Shutdown
- Cycle-by-Cycle Over Current Protection
- Wide 4.75 to 15V operating input range
- Output Adjustable from 1.22 to 13V
- Programmable Under Voltage Lockout
- Available in 8-Pin SOIC

### APPLICATIONS

PC Monitors  
Distributed Power Systems  
Battery Charger  
Pre-Regulator for Linear Regulators

### ORDERING INFORMATION

Order Number	Package Type	Temperature Range	Marking	QTY/Reel
--------------	--------------	-------------------	---------	----------

### TYPICAL OPERATING CIRCUIT

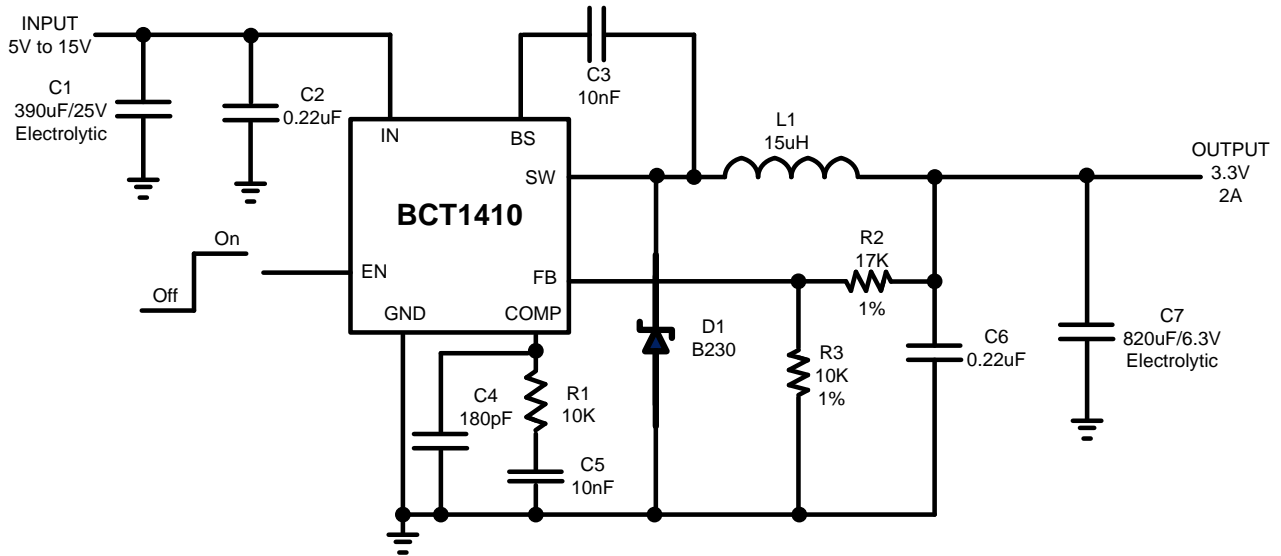

Ver 1.0

## PIN CONFIGURATION

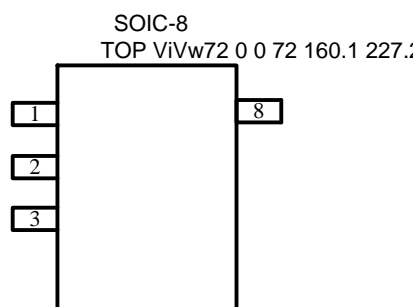

## PIN DESCRIPTION

PIN	NAME	FUNCTION
1	BS	High-Side Gate Drive Boost Input. BS supplies the drive for the high-side N-Channel MOSFET switch. Connect a 0.01 $\mu$ F or greater capacitor from SW to BS to power the high side switch.
2	IN	Power Input. IN supplies the power to the IC, as well as the step-down converter switches. Drive IN with a 4.75V to 15V power source. Bypass IN to GND with a suitably large capacitor to eliminate noise on the input to the IC. See Input Capacitor.
3	SW	Power Switching Output. SW is the switching node that supplies power to the output. Connect the output LC filter from SW to the output load. Note that a capacitor is required from SW to BS to power the high-side switch.
4	GND	Ground.
5	FB	Feedback Input. FB senses the output voltage to regulate that voltage. Drive FB with a resistive voltage divider from the output voltage. The feedback threshold is 1.22V. See Setting the Output Voltage.
6	COMP	Compensation Node. COMP is used to compensate the regulation control loop. Connect a series RC network from COMP to GND to compensate the regulation control loop. In some cases, an additional capacitor from COMP to GND is required. See Compensation Components.
7	EN	Enable Input. EN is a digital input that turns the regulator on or off. Drive EN high to turn on the regulator, drive it low to turn it off. Pull up with 100k resistor for automatic startup.
8	NC	No Connect

Ver 1.0

## ELECTRICAL CHARACTERISTICS

( $V_{IN}=12V$ ,  $V_{EN}=5V$ ,  $T_A=25^{\circ}C$ , unless otherwise specified.)

PARAMETER	SYM	CONDITIONS	MIN	TYP	MAX	UNITS
Feedback Voltage	$V_{FB}$	$4.75V \leq V_{IN} \leq 15V$	1.184	1.222	1.258	V
Upper Switch On Resistance	$R_{DS(ON)1}$			0.22		
Lower Switch On Resistance	$R_{DS(ON)2}$			10		
Upper Switch Leakage		$V_{EN}=0V$ , $V_{SW}=0V$			10	$\mu A$
Current Limit			2.4	2.95		A
Oscillation Frequency	$F_{OSC1}$		320	380	440	kHz
Short Circuit Frequency		$V_{FB}=0V$		42		kHz
Maximum Duty Cycle	$D_{MAX}$	$V_{FB}=1.0V$		90		%
Minimum Duty Cycle	$D_{MIN}$	$V_{FB}=1.5V$			0	%
EN Threshold		$V_{EN}$ Rising	0.7	1.0	1.3	V
Input Under Voltage Lockout Threshold		$V_{IN}$ Rising	2.0	2.5	3.0	V
Input Under Voltage Lockout Threshold Hysteresis				200		mV
Shutdown Supply Current	$I_{SHDN}$	$V_{EN}=0V$		25	50	$\mu A$
Operating Supply Current		$V_{EN}=0V$ , $V_{FB}=1.4V$		1.0	1.5	mA
Thermal Shutdown				160		$^{\circ}C$

## FUNCTION BLOCK DIAGRAM

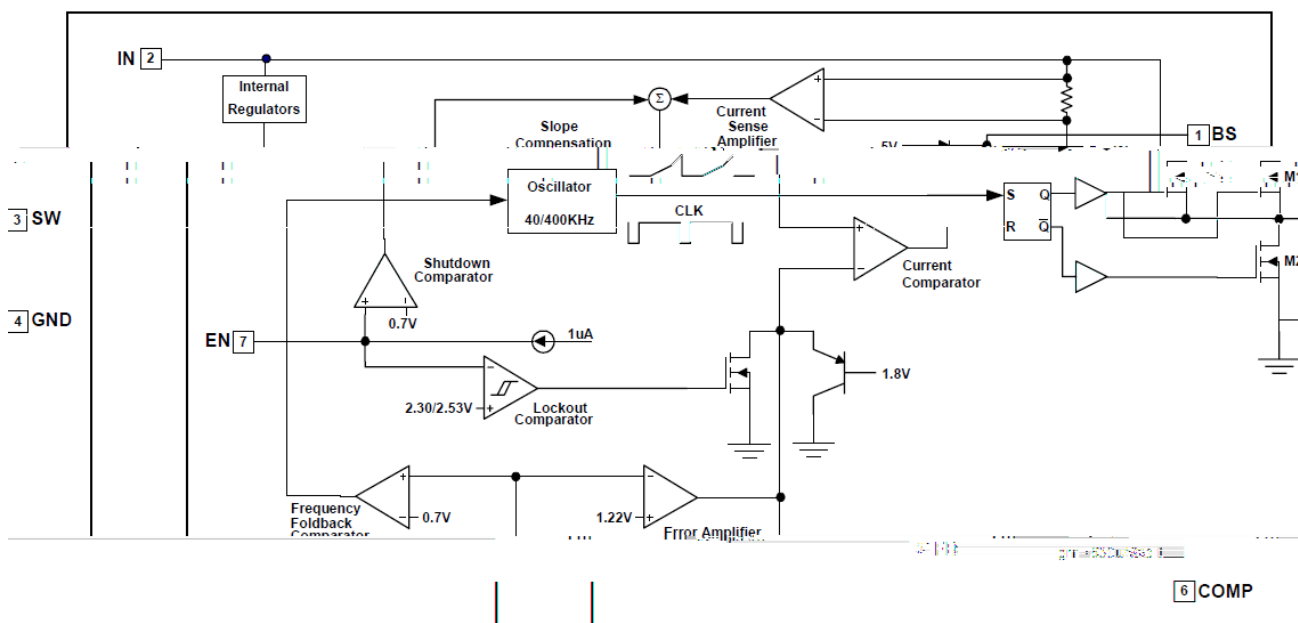

Figure 1. Function Block Diagram

## OPERATION FUNCTIONAL DESCRIPTION

The BCT1410 is a current-mode step-down switch-mode regulator. It regulates input voltages from 4.75V to 15V down to an output voltage as low as 1.22V, and is able to supply up to 2A of load current. The BCT1410 uses current-mode control to regulate the output voltage. The output voltage is measured at FB through a resistive voltage divider and amplified through the internal error amplifier. The output current of the transconductance error amplifier is presented at COMP where a network compensates the regulation control system. The voltage at COMP is compared to the switch

current measured internally to control the output voltage.

The converter uses an internal n-channel MOSFET switch to step down the input voltage to the regulated output voltage. Since the MOSFET requires a gate voltage greater than the input voltage, a boost capacitor connected between SW and BS drives the gate. The capacitor is internally charged while the switch is off. An internal 10 Ω switch from SW to GND is used to insure that SW is pulled to GND when the switch is off to fully charge the BS capacitor.

**APPLICATION INFORMATION**

**COMPONENT SELECTION**

**Setting the Output Voltage**

The output voltage is set using a resistive voltage divider from the output voltage to FB pin. The voltage divider divides the output voltage down to the feedback voltage by the ratio:

$$V_{FB} = V_{OUT} \frac{R3}{R2 + R3}$$

Where  $V_{FB}$  is the feedback voltage and  $V_{OUT}$  is the output voltage.

Thus the output voltage is:

$$V_{OUT} = 1.222 \frac{R2 + R3}{R3}$$

$R3$  can be as high as 100k , but a typical value is 10k . Using the typical value for  $R2$ ,  $R1$  is determined by:

$$R2 = 8.18 \times (V_{OUT} - 1.222)(k\Omega)$$

For example, for a 3.3V output voltage,  $R3$  is 10k , and  $R2$  is 17k .

**Inductor**

The inductor is required to supply constant current to the output load while being driven by the switched input voltage. A larger value inductor will result in less ripple current that will result in lower output ripple voltage. However, the larger value inductor will have a larger physical size, higher series resistance, and/or lower saturation current. A good rule for determining the inductance to use is to allow the peak-to-peak ripple current in the inductor to be approximately 30% of the maximum load current. Also, make sure that the peak inductor current is below the maximum switch current limit. The inductance value can be calculated by:

$$L = \frac{V_{OUT}}{f_S \times \Delta I_L} \times \left(1 - \frac{V_{OUT}}{V_{IN}}\right)$$

Where  $V_{OUT}$  is the output voltage,  $V_{IN}$  is the input voltage,  $f_S$  is the switching frequency, and  $I_L$  is

the peak-to-peak inductor ripple current.

Choose an inductor that will not saturate under the maximum inductor peak current. The peak inductor current can be calculated by:

$$I_{LP} = I_{LOAD} + \frac{V_{OUT}}{2 \times f_S \times L} \times \left(1 - \frac{V_{OUT}}{V_{IN}}\right)$$

Where  $I_{LOAD}$  is the load current.

The choice of which style inductor to use mainly depends on the price vs. size requirements and any EMI requirements.

**Schottky Diode**

During the transition between high-side switch and low-side switch, the body diode of the

## Ver 1.0

best performance. Ceramic capacitors are preferred, but tantalum or low-ESR electrolytic capacitors may also suffice. Choose X5R or X7R dielectrics when using ceramic capacitors.

Since the input capacitor (C1) absorbs the input switching current it requires an adequate ripple current rating. The RMS current in the input capacitor can be estimated by:

$$I_{C1} = I_{LOAD} \times \sqrt{\frac{V_{OUT}}{V_{IN}} \times \left(1 - \frac{V_{OUT}}{V_{IN}}\right)}$$

The worst-case condition occurs at  $V_{IN} = 2V_{OUT}$ , where  $I_{C1} = I_{LOAD}/2$ . For simplification, choose the input capacitor whose RMS current rating greater than half of the maximum load current. The input capacitor can be electrolytic, tantalum or ceramic. When using electrolytic or tantalum capacitors, a small, high quality ceramic capacitor, i.e. 0.1 $\mu$ F, should be placed as close to the IC as possible. When using ceramic capacitors, make sure that they have enough capacitance to provide sufficient charge to prevent excessive voltage ripple at input. The input voltage ripple for low ESR capacitors can be estimated by:

$$\Delta V_{IN} = \frac{I_{LOAD}}{C1 \times f_S} \times \frac{V_{OUT}}{V_{IN}} \times \left(1 - \frac{V_{OUT}}{V_{IN}}\right)$$

Where C1 is the input capacitance value.

For insuring stable operation C1 should be placed as close to the IC as possible. Alternately a smaller high quality ceramic 0.1 $\mu$ F capacitor maybe placed closer to the IC and a larger capacitor placed further away. If using this technique, it is recommended that the larger capacitor be a tantalum or electrolytic type. All ceramic capacitors should be close to the BCT1410.

### Output Capacitor

The output capacitor is required to maintain the DC output voltage. Ceramic, tantalum, or low

ESR electrolytic capacitors are recommended. Low ESR capacitors are preferred to keep the output voltage ripple low. The output voltage ripple can be estimated by:

$$\Delta V_{OUT} = \frac{V_{OUT}}{f_S \times L} \times \left(1 - \frac{V_{OUT}}{V_{IN}}\right) \times \left(R_{ESR} + \frac{1}{8 \times f_S \times C2}\right)$$

Where C2 is the output capacitance value and  $R_{ESR}$  is the equivalent series resistance (ESR) value of the output capacitor.

In the case of ceramic capacitors, the impedance at the switching frequency is dominated by the capacitance. The output voltage ripple is mainly caused by the capacitance. For simplification, the output voltage ripple can be estimated by:

$$\Delta V_{OUT} = \frac{V_{OUT}}{8 \times f_S^2 \times L \times C2} \times \left(1 - \frac{V_{OUT}}{V_{IN}}\right)$$

In the case of tantalum or electrolytic capacitors, the ESR dominates the impedance at the switching frequency. For simplification, the output ripple can be approximated to:

$$\Delta V_{OUT} = \frac{V_{OUT}}{f_S \times L} \times \left(1 - \frac{V_{OUT}}{V_{IN}}\right) \times R_{ESR}$$

The characteristics of the output capacitor also affect the stability of the regulation system. The BCT1410 can be optimized for a wide range of capacitance and ESR values.

### Compensation Components

BCT1410 employs current mode control for easy compensation and fast transient response. The system stability and transient response are controlled through the COMP pin. COMP pin is the output of the internal transconductance error amplifier. A series capacitor-resistor combination sets a pole-zero combination to control the characteristics of the control system.

The DC gain of the voltage feedback loop is

## Ver 1.0

given by:

$$A_{VDC} = R_{LOAD} \times G_{CS} \times A_{EA} \times \frac{V_{FB}}{V_{OUT}}$$

Where  $V_{FB}$  is the feedback threshold voltage, 1.222V

$V_{OUT}$  is the desired output regulation voltage

$A_{VEA}$  is the error amplifier voltage gain, 400V/V;

$G_{CS}$  is the current sense gain, (roughly the output current divided by the voltage at COMP), 1.95A/V

$R_{LOAD}$  is the load resistor value ( $V_{OUT}/I_{OUT}$  where  $I_{OUT}$  is the output load current)

The system has two poles of importance. One is due to the compensation capacitor (C5) and the output resistor of the error amplifier, and the other is due to the output capacitor (C7) and the load resistor. These poles are located at:

$$f_{P1} = \frac{G_{EA}}{2\pi \times C5 \times A_{VEA}}$$

$$f_{P2} = \frac{1}{2\pi \times C7 \times R_{LOAD}}$$

Where  $G_{EA}$  is the error amplifier transconductance. The system has one zero of importance, due to the compensation capacitor (C5) and the compensation resistor (R1). This zero is located at:

$$f_{Z1} = \frac{1}{2\pi \times C5 \times R1}$$

The system may have another zero of importance, if the output capacitor has a large capacitance and/or a high ESR value. The zero, due to the ESR and capacitance of the output capacitor can be compensated by a third pole set by R1 and C4:

$$f_{P3} = \frac{1}{2\pi \times C4 \times R1}$$

The system crossover frequency (the frequency where the loop gain drops to 1, or 0dB) is

important. A good rule of thumb is to set the crossover frequency below one-tenth of the switching frequency. In this case, the switching frequency is 380KHz, so use a crossover frequency,  $f_c$ , of 40KHz. Lower crossover frequencies result in slower response and worse transient load recovery. Higher crossover frequencies can result in instability.

**Table 1: Compensation Values for Typical Output Voltage/Capacitor Combinations**

$V_{OUT}$	C7	R1	C3	C4
2.5V	22uF Ceramic	7.5k	2.2nF	None
3.3V	22uF Ceramic	10k	1.5nF	None
5V	22uF Ceramic	10k	2.2nF	None
12V	22uF Ceramic	10k	2.7nF	None
2.5V	560uF/6.3V (30m ESR)	10k	15nF	1.5nF
3.3V	560uF/6.3V (30m ESR)	10k	18nF	1.5nF
5V	470uF/10V (30m ESR)	10k	27nF	1.5nF
12V	220uF/25V (30m ESR)	10k	27nF	680pF

### Choosing the Compensation Components

The values of the compensation components given in Table 1 yield a stable control loop for the output voltage and capacitor given.

To optimize the compensation component  $T_m$  (the )-86(com)



## Ver 1.0

The value of R1 is limited to 10K to prevent output overshoot at startup, so if the value calculated for R1 is greater than 10K, use 10K. In this case, the actual crossover frequency is less than the desired 40kHz, and is calculated by:

$$f_c = \frac{R1 * G_{EA} * G_{CS} * V_{FB}}{2\pi * C7 * V_{OUT}}$$

Or

$$f_c \approx \frac{2.92}{C7 * V_{OUT}}$$

Choose the compensation capacitor to set the zero to 1/4 of the crossover frequency. Determine the value by the following equation:

$$C5 = \frac{2}{\pi * R1 * f_c} \approx \frac{1.59 \times 10^{-5}}{R1}$$

If R1 is less than 10 K, or if R1=10 K use the following equation:

$$C5 = \frac{4C7 * V_{OUT}}{R1^2 * G_{EA} * G_{CS} * V_{FB}}$$

$$C5 \approx 2.2 \times 10^{-5} C7 * V_{OUT}$$

Determine if the second compensation capacitor, C4 is required. It is required if the ESR zero of the output capacitor happens at less than four times the crossover frequency.

Or:

$$8\pi * C7 * R_{ESR} * f_c \geq 1$$

Where  $R_{ESR}$  is the equivalent series resistance of the output capacitor. If this is the case, then add the second compensation resistor. Determine the value by the equation:

$$C4 = \frac{C7 * R_{ESR(max)}}{R1}$$

Where  $R_{ESR(MAX)}$  is the maximum ESR of the output capacitor.

### Example:

$V_{OUT} = 3.3V$

$C7 = 22\mu F$  Ceramic (ESR=10m)

$$R1 \approx (1.37 \times 10^8)(22 \times 10^{-6})(3.3V) = 9.9K\Omega$$

Use the nearest standard value of 10K.

$$C5 \approx 1.59 \times 10^{-5} / 10K\Omega = 1.6nF$$

Use the nearest standard value of 1.5nF.

$$2\pi * C7 * R_{ESR} * f_c = 0.55$$

Which is less than 1, therefore no second compensation capacitor is required.

TYPICAL APPLICATION CIRCUIT

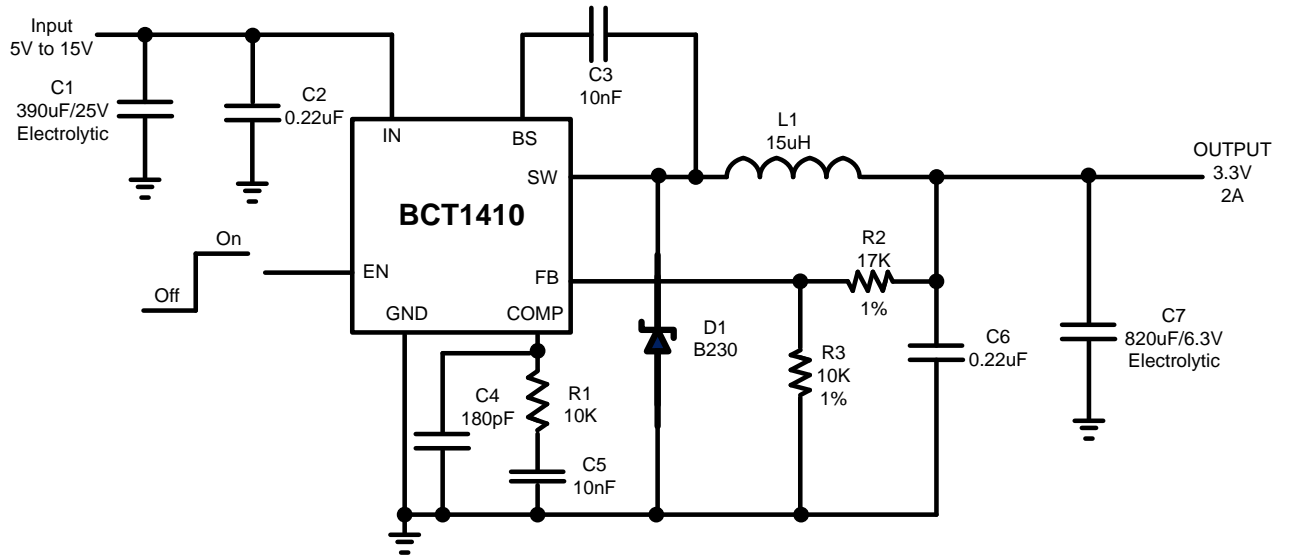

Figure 2. BCT1410 Step down from 15V to 3.3V @2A

Ver 1.0

---

## **PCB LAYOUT GUIDE**

PCB layout is very important to achieve stable operation. It is highly recommended to duplicate EVB layout for optimum performance.

If change is necessary, please follow these guidelines.

- 1) Keep the path of switching current short and minimize the loop area formed by input cap, high-side MOSFET and low-side MOSFET.
- 2) Bypass ceramic capacitors are suggested to be put close to the Vin Pin.

- 3) Ensure all feedback connections are short and direct. Place the feedback resistors and compensation components as close to the chip as possible.

- 4) Route SW away from sensitive analog areas such as FB.

- 5) Connect IN, SW, and especially GND respectively to a large copper area to cool the chip to improve thermal performance and long-term reliability.

**PACKAGE OUTLINE DIMENSIONS**

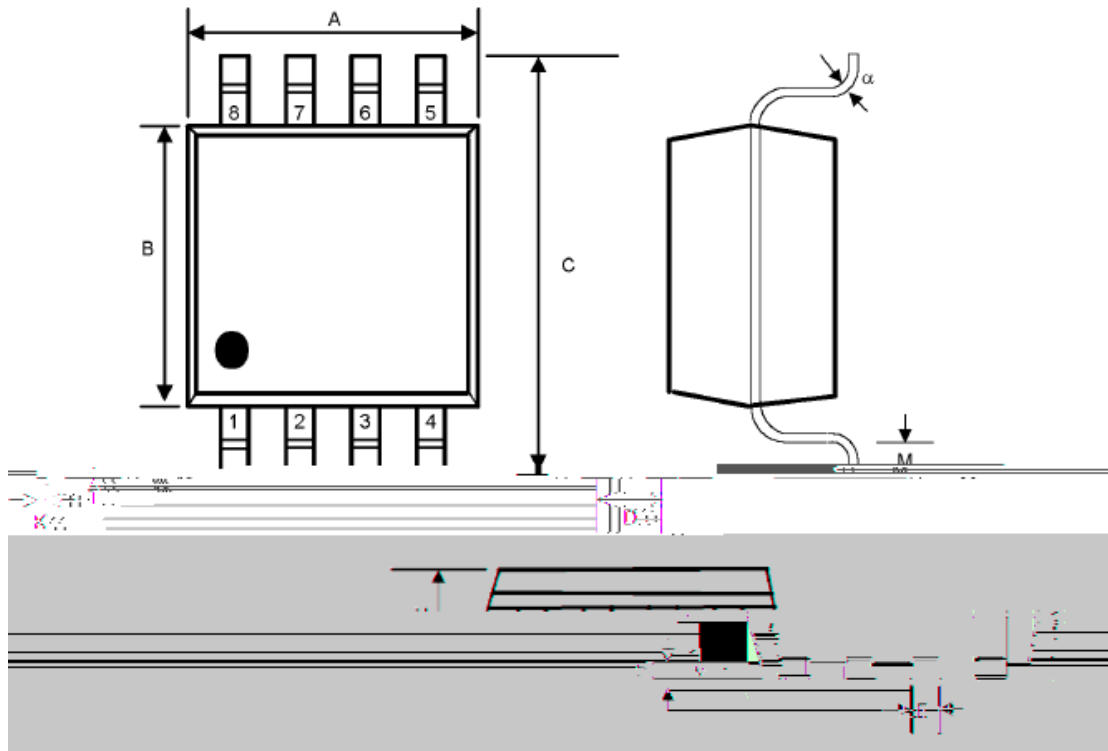

Symbol	Dimensions In Millimeters		Dimensions In Inches	
	Min	Max	Min	Max
A	4.80	5.00	0.188	0.197
B	3.80	4.00	0.149	0.158
C	5.80	6.20	0.228	0.244
D	1.27 BSC		0.050	
E	0.33	0.51	0.013	0.020
F	0.10	0.25	0.004	0.010
H	1.35	1.75	0.053	0.069
K	0.19	0.25	0.007	0.010
M	0.40	1.27	0.016	0.050
	0°	8°	0°	8°

**SOP-8 Surface Mount Package**